

# TESTE ANGOLARI 90° MULTI-WAY

## 90° MULTI-WAY ANGLE HEADS



# TESTE ANGOLARI 90° MULTI-WAY 90° MULTI-WAY ANGLE HEADS

FORATURA  
DRILLING



MASCHIATURA  
TAPPING



REFRIGERANTE  
COOLANT



CARICAMENTO  
LOADING



## SPECIFICHE TECNICHE TECHNICAL FEATURES

Modello <i>Type</i>	A25/20-SK40
Codice <i>Code</i>	128909.100
Modello <i>Type</i>	A25/20-BT40
Codice <i>Code</i>	128910.100
Modello <i>Type</i>	A25/20-CAT40
Codice <i>Code</i>	128913.100
Mandrino per pinza <i>Spindle for collet</i>	ER 25/ER 20
Rotazione presa di forza <i>Main drive rotation</i>	DX / LH
Rotazione mandrino <i>Spindle rotation</i>	DX / RH
Rapporto di trasmissione <i>Transmission ratio</i>	1:1
Velocità max <i>Max speed</i>	5000 rpm
Coppia mandrini ER 25 <i>Torque ER 25 spindle</i>	19 Nm
Lubrificata a grasso <i>Grease lubricated</i>	Klüber Isoflex NBU 15

## OPTIONAL OPTIONAL

Pinza ER20 DIN 6499/B <i>ER20 collet DIN 6499/B</i>	411220.100
Pinza ER25 DIN 6499/B <i>ER25 collet DIN 6499/B</i>	411225.100

## CODICE CODE

## DOTAZIONE STANDARD STANDARD EQUIPMENT

Stop-block standard <i>Standard stop-block</i>	311201.025
Chiave <i>Clamping wrench</i>	
Tubetto di grasso <i>Grease tube</i>	
Bauletto <i>Storage case</i>	

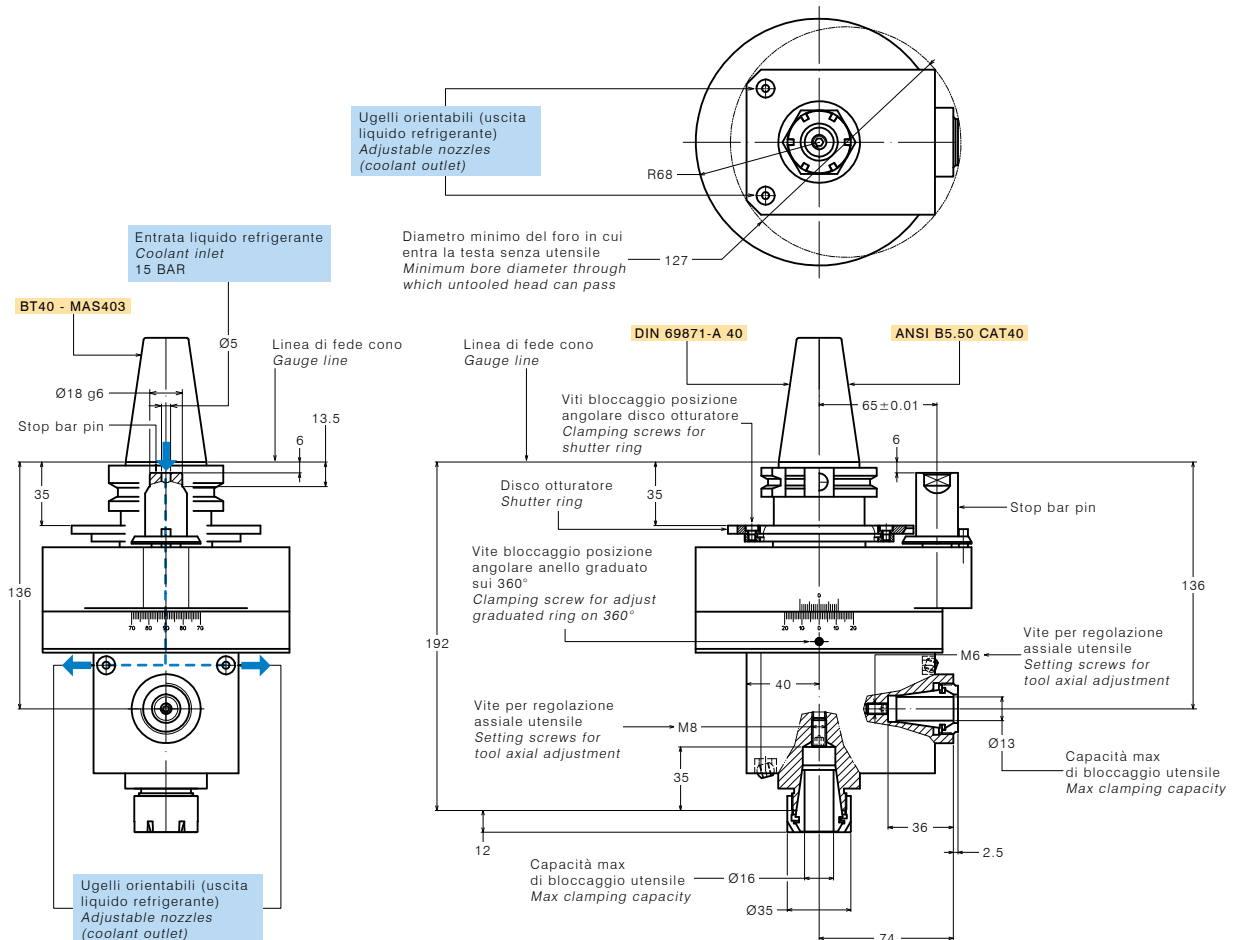

**TESTE ANGOLARI 90° MULTI-WAY  
90° MULTI-WAY ANGLE HEADS**



**SPECIFICHE TECNICHE TECHNICAL FEATURES**

Modello *Type* A25/20-**HSK63**  
 Codice *Code* 128914.100  
 Mandrino per pinza *Spindle for collet* ER 25/ER 20  
 Rotazione presa di forza *Main drive rotation* DX / LH  
 Rotazione mandrino *Spindle rotation* DX / RH  
 Rapporto di trasmissione *Transmission ratio* 1:1  
 Velocità max *Max speed* 5000 rpm  
 Coppia mandrini ER 25 *Torque ER 25 spindle* 19 Nm  
 Lubrificata a grasso *Grease lubricated* Klüber Isoflex NBU 15

**OPTIONAL OPTIONAL**

Pinza ER20 DIN 6499/B  
 ER20 collet DIN 6499/B  
 Pinza ER25 DIN 6499/B  
 ER25 collet DIN 6499/B

**CODICE CODE**

411220.100  
 411225.100

**DOTAZIONE STANDARD STANDARD EQUIPMENT**

Stop-block standard *Standard stop-block* 311201.025  
 Chiave *Clamping wrench*  
 Tubetto di grasso *Grease tube*  
 Bauletto *Storage case*

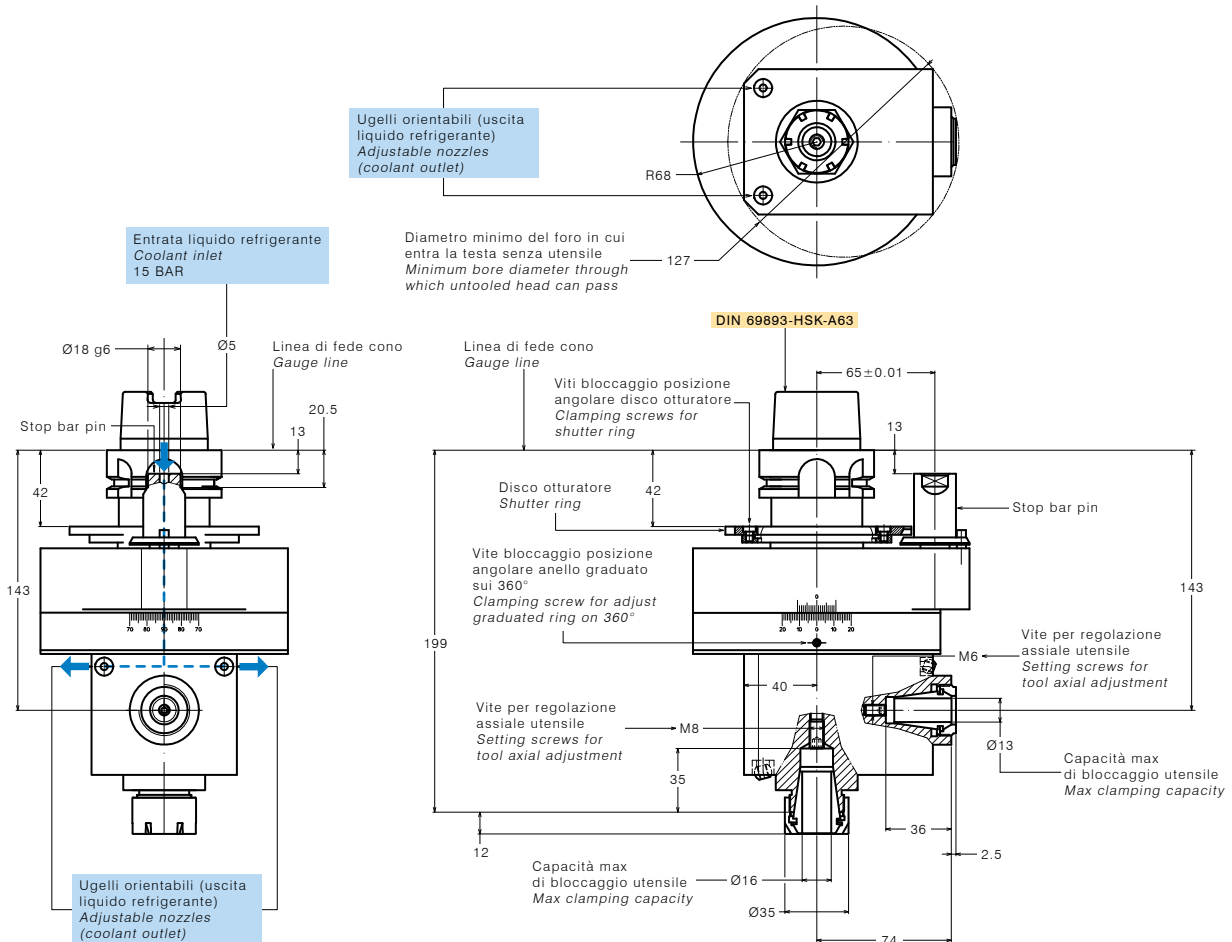

**TESTE ANGOLARI 90° MULTI-WAY**  
**90° MULTI-WAY ANGLE HEADS**



**SPECIFICHE TECNICHE TECHNICAL FEATURES**

Modello <i>Type</i>	A32/25-25-SK50
Codice <i>Code</i>	128903.100
Modello <i>Type</i>	A32/25-25-BT50
Codice <i>Code</i>	128904.100
Modello <i>Type</i>	A32/25-25-CAT50
Codice <i>Code</i>	128907.100
Mandrino per pinza <i>Spindle for collet</i>	ER 32/ER 25 - ER 25
Rotazione presa di forza <i>Main drive rotation</i>	DX / LH
Rotazione mandrino <i>Spindle rotation</i>	DX / RH
Rapporto di trasmissione <i>Transmission ratio</i>	1:1
Velocità max <i>Max speed</i>	4000 rpm
Coppia mandrini ER 25 <i>Torque ER 25 spindle</i>	31 Nm
Peso <i>Weight</i>	15.6 Kg
Lubrificata a grasso <i>Grease lubricated</i>	Klüber Isoflex NBU 15

**OPTIONAL OPTIONAL**

Pinza ER25 DIN 6499/B <i>ER25 collet DIN 6499/B</i>	411225.100
Pinza ER32 DIN 6499/B <i>ER32 collet DIN 6499/B</i>	411232.100

**DOTAZIONE STANDARD STANDARD EQUIPMENT**

Stop-block standard <i>Standard stop-block</i>	311201.025
Chiave <i>Clamping wrench</i>	
Tubetto di grasso <i>Grease tube</i>	
Bauletto <i>Storage case</i>	

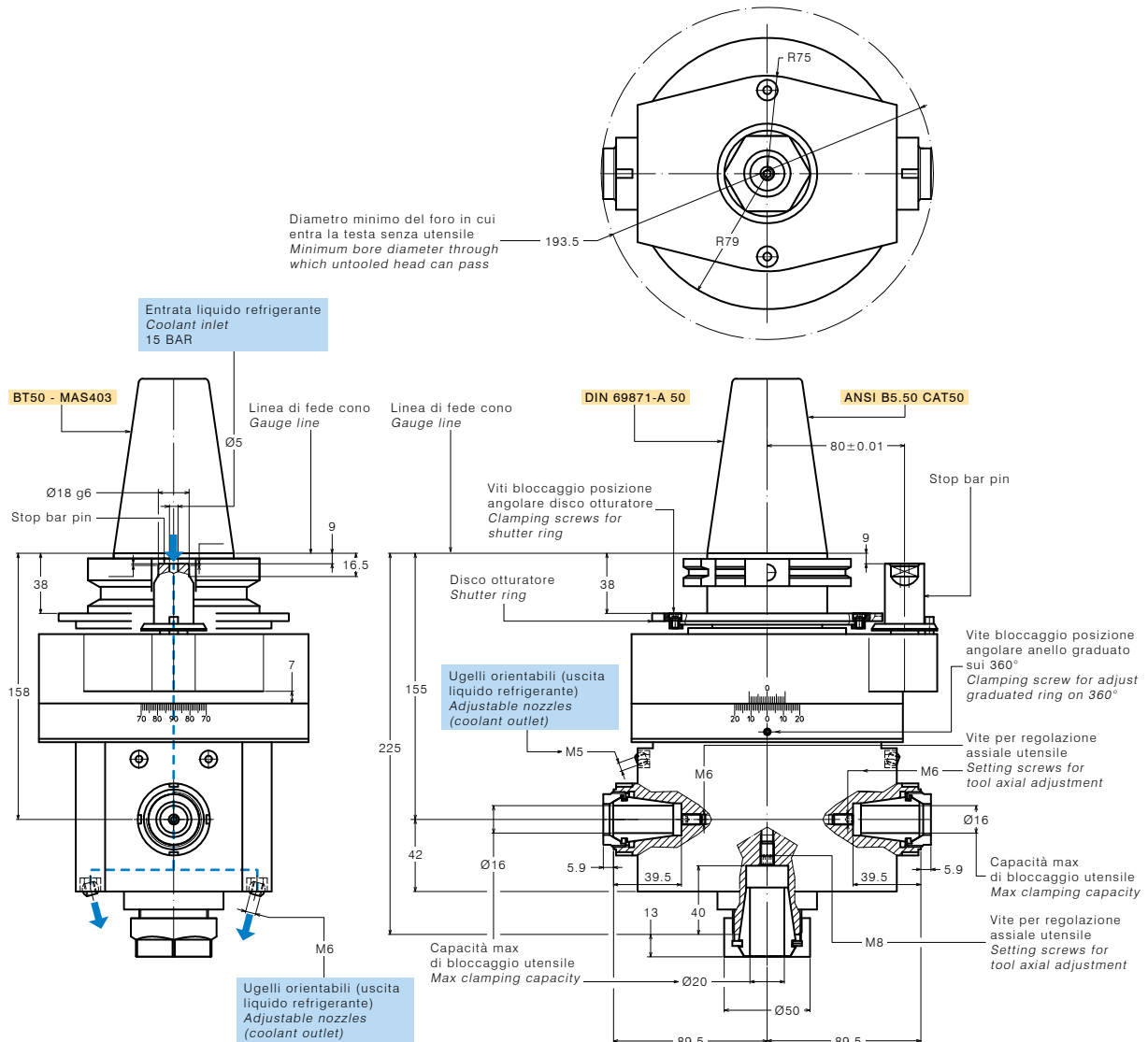

**TESTE ANGOLARI 90° MULTI-WAY**  
**90° MULTI-WAY ANGLE HEADS**



**SPECIFICHE TECNICHE TECHNICAL FEATURES**

Modello <i>Type</i>	A32/25-25- <b>HSK100</b>
Codice <i>Code</i>	128908.100
Mandrino per pinza <i>Spindle for collet</i>	ER 32/ER 25 - ER 25
Rotazione presa di forza <i>Main drive rotation</i>	DX / LH
Rotazione mandrino <i>Spindle rotation</i>	DX / RH
Rapporto di trasmissione <i>Transmission ratio</i>	1:1
Velocità max <i>Max speed</i>	4000 rpm
Coppia mandrini ER 25 <i>Torque ER 25 spindle</i>	31 Nm
Peso <i>Weight</i>	15.6 Kg
Lubrificata a grasso <i>Grease lubricated</i>	Klüber Isoflex NBU 15

**OPTIONAL OPTIONAL**

Pinza ER25 DIN 6499/B	411225.100
ER25 collet DIN 6499/B	
Pinza ER32 DIN 6499/B	411232.100
ER32 collet DIN 6499/B	

**CODICE CODE**

**DOTAZIONE STANDARD STANDARD EQUIPMENT**

Stop-block standard <i>Standard stop-block</i>	311201.025
Chiave <i>Clamping wrench</i>	
Tubetto di grasso <i>Grease tube</i>	
Bauletto <i>Storage case</i>	

