

TESTE ANGOLARI 90° DISASSATE

90° OFF-SET ANGLE HEADS



TESTE ANGOLARI 90° DISASSATE
90° OFF-SET ANGLE HEADS

FORATURA
DRILLING



MASCHIATURA
TAPPING



REFRIGERANTE
COOLANT



CARICAMENTO
LOADING



SPECIFICHE TECNICHE TECHNICAL FEATURES

Modello <i>Type</i>	AO25-SK40-S195
Codice <i>Code</i>	1249108.100
Modello <i>Type</i>	AO25-BT40-S201
Codice <i>Code</i>	1249109.100
Modello <i>Type</i>	AO25-CAT40-S195
Codice <i>Code</i>	1249110.100
Mandrino <i>Spindle</i>	ER25
Rotazione presa di forza <i>Main drive rotation</i>	SX / LH
Rotazione mandrino <i>Spindle rotation</i>	DX / RH
Rapporto di trasmissione <i>Transmission ratio</i>	1:1
Velocità max <i>Max speed</i>	6000 rpm
Coppia max <i>Max torque</i>	23 Nm
Spinta max mandrino <i>Spindle max thrust</i>	230 N
Peso <i>Weight</i>	6.5 Kg
Lubrificata a grasso <i>Grease lubricated</i>	Klüber Isoflex NBU 15

OPTIONAL OPTIONAL

Pinza ER25 DIN 6499/B <i>ER25 collet DIN 6499/B</i>	411225.100
Pinza di maschiatura ET-1-25 con compensazione <i>Tapping collet ET-1-25 with compensation</i>	401225.200
Pinza di maschiatura ER25 con quadro <i>Tapping collet ER25 with square</i>	411225.200

CODICE CODE

DOTAZIONE STANDARD STANDARD EQUIPMENT

Stop-block standard <i>Standard stop-block</i>	311201.025
Chiave <i>Clamping wrench</i>	
Tubetto di grasso <i>Grease tube</i>	
Bauletto <i>Storage case</i>	

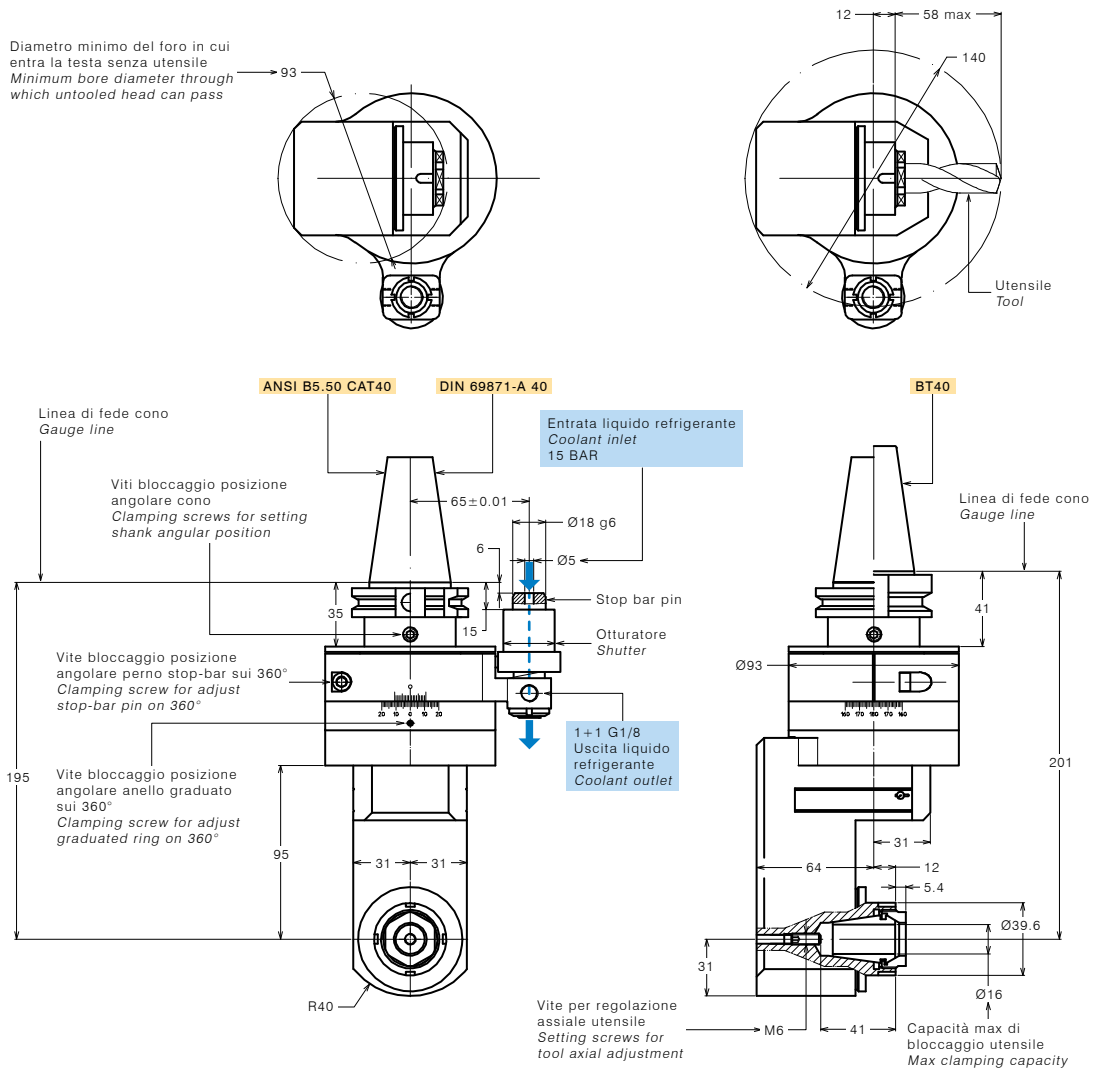

TESTE ANGOLARI 90° DISASSATE
90° OFF-SET ANGLE HEADS

REFRIGERANTE
 COOLANT



CARICAMENTO
 LOADING



SPECIFICHE TECNICHE TECHNICAL FEATURES

Modello <i>Type</i>	AO27-HSK100
Codice <i>Code</i>	124504.100
Mandrino <i>Spindle</i>	DIN 6358 Ø27
Rotazione presa di forza <i>Main drive rotation</i>	DX / RH
Rotazione mandrino <i>Spindle rotation</i>	DX / RH
Rapporto di trasmissione <i>Transmission ratio</i>	1:1
Velocità max <i>Max speed</i>	3500 rpm
Potenza max mandrino <i>Spindle max power</i>	35 Nm
Peso <i>Weight</i>	14 Kg
Lubrificata a grasso <i>Grease lubricated</i>	Klüber Isoflex NBU 15

DOTAZIONE STANDARD STANDARD EQUIPMENT

Stop-block standard <i>Standard stop-block</i>	311201.026
Tubetto di grasso <i>Grease tube</i>	
Bauletto <i>Storage case</i>	

